



## Streamline Series with Air Gap Eductors

### Package Contains:

1. Proportioner unit.
2. Supply tube — 2.1 M. per eductor.
3. Foot valve assembly and weight — one for each eductor.
4. Inner and outer discharge tubes — one for each eductor.
5. Metering tip kit(s).
6. Mounting anchor kit.
7. Hook(s) for discharge tube(s) -- models with 14 IPM eductors
8. Instruction sheet with parts list/diagram.

### Installation and Operation:

Repeat the following procedures as necessary for the number of eductors your unit contains.

1. Remove cabinet cover. Install the short, white inner discharge tube in the outlet of the eductor. It goes over the smaller barbed part which is inside the outlet end of the eductor. This tube must be in place for the eductor to function. The inner discharge tube for a 14 LPM (yellow) eductor has a yellow flooding ring inside it. The inner discharge tube for a 4 LPM (grey) eductor has a grey flooding ring inside it. Install the end of the tube nearest the flooding ring on the eductor's inner discharge barb.
2. Drill holes for the three wall anchors with a 7mm drill, using the cabinet back as a template for correct spacing of the mounting screws. Install mounting anchors, and then screws in top two anchors. Slide key holes in cabinet back over screw heads. Tighten screws and install third (bottom) screw. Do not mount more than 1.8 m above bottom of concentrate container, nor below the highest concentrate level (never mount your concentrate higher than the unit).
3. Select a metering tip for each eductor (see next section) and insert the tip into the hose barb on the eductor body.
4. Supply tube should reach from hose barb on eductor to bottom of concentrate container. If using more than one eductor, cut supply tube provided to lengths required. Slide ceramic weight over one end of the tube and slide foot valve into the same end of the tube.
5. Slip open end of supply tube through an opening in either side of the cabinet and push over the hose barb/metering tip on the eductor.
6. A short discharge tube is used with 4 LPM eductors; minimum hose length is 20 cm for correct operation. Longer (1.2 m.) hoses are used with 14 LPM eductors. Slide tube over inner tube previously installed in eductor discharge outlet. Clamps for securing the 14 LPM tubes are provided. Hooks are provided to allow longer discharge tubes to conveniently hang from the side cabinet openings.
7. Place foot valve end of supply tube into concentrate container. **REMEMBER TO CHECK FOOT VALVE STRAINER PERIODICALLY FOR CLOGGING: CLEAN IF NECESSARY.**
8. Replace cabinet cover and screws.
9. Connect water supply hose of at least 13mm ID to water inlet swivel. (Minimum 1.76 Bar pressure, **with water running**, is required for correct operation.) Connect other end of hose to water supply. Turn water supply on.
10. Purge air from the system by depressing the buttons briefly. There may be some water discharge from the eductor vents until the air is purged.
11. Push button to start flow of desired water/concentrate solution, and hold until supply tube is primed (filled). Then push the button whenever dispensing is desired, and release button to stop flow of solution. Optional twist-to-latch buttons are available for continuous dispensing without holding button.
12. **It is essential that the discharge hose is not obstructed. If discharge is restricted, water will flow out of the eductor vents. Do not start to operate the dispenser with liquid in the discharge tube.**

**Metering Tip Selection:**

The final concentration of the dispensed solution is related to both the size of the metering tip opening and the viscosity of the liquid being siphoned. For water-thin products, the chart at left can be used as a guideline. If product is noticeably thicker than water, consult the Measurement of Concentration Procedure below to achieve your desired water-to-product ratio. Because dilution can vary with water temperature and pressure, actual dilution achieved can only be ascertained by using the Measurement of Concentration Procedure. The clear, undrilled tip is provided to permit drilling to size not listed should you need a dilution ratio that falls between standard tip sizes.

**NOTE:** A 4 LPM eductor is grey; a 14 LPM eductor is yellow. Refer to parts diagram if unfamiliar with names of system components.

**Measurement of Concentration:**

You can determine the dispensed water-to-product ratio for any metering tip size and product viscosity. All that is required is to operate the primed dispenser for a minute or so and note two things: the amount of dispensed solution, and the amount of concentrate used in preparation of the solution dispensed. The water-to-product ratio is then calculated as follows:

$$\text{Dilution Ratio (X:1) where X} = \frac{\text{Amount of Mixed Solution} - \text{Amount of Concentrate Drawn}}{\text{Amount of Concentrate Drawn}}$$

Dilution Ratio, then, equals X parts water to one part concentrate (X:1). If the test does not yield the desired ratio, choose a different tip and repeat the test. Alternative methods to this test are 1) pH (using litmus paper), and 2) titration. Contact your concentrate supplier for further information on these alternative methods and the materials required to perform them.

**Streamline Parts Diagram:  
3-button unit illustrated**

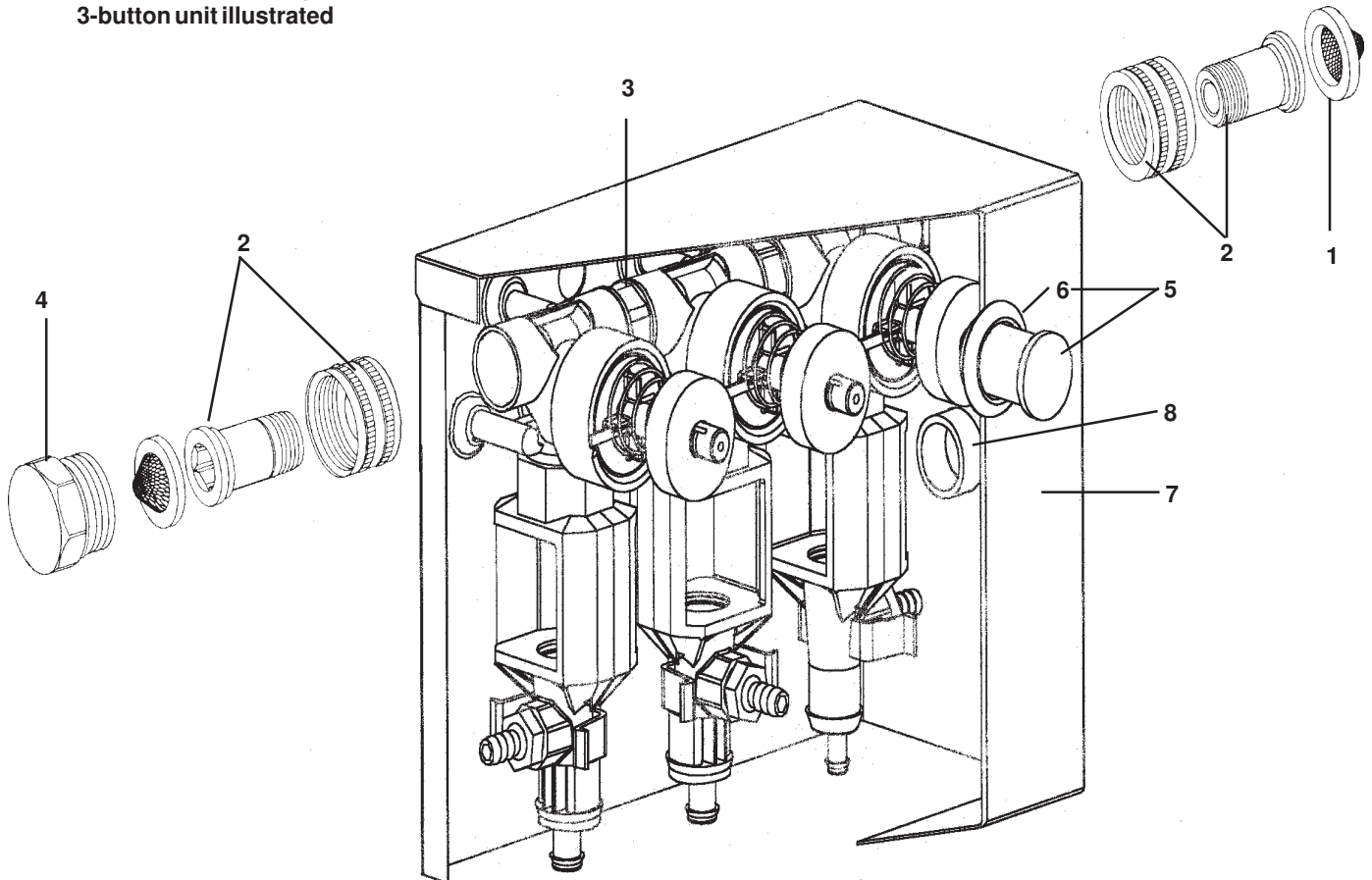

Tip Color	Orifice Size	Std. Drill Number	Ratio (per Eductor Flow)	
			4 LPM	14 LPM
No Tip	.187	(3/16)	3:1	3.5:1
Grey	.128	(30)	3:1	4:1
Black	.098	(40)	3:1	4:1
Beige	.070	(50)	4:1	8:1
Red	.052	(55)	5:1	14:1
White	.043	(57)	7:1	20:1
Blue	.040	(60)	8:1	24:1
Tan	.035	(65)	10:1	30:1
Green	.028	(70)	16:1	45:1
Orange	.025	(72)	20:1	56:1
Brown	.023	(74)	24:1	64:1
Yellow	.020	(76)	32:1	90:1
Aqua	.018	(77)	38:1	128:1
Purple	.014	(79)	64:1	180:1
Pink	.010	(87)	128:1	350:1

**Parts Diagram/List:**

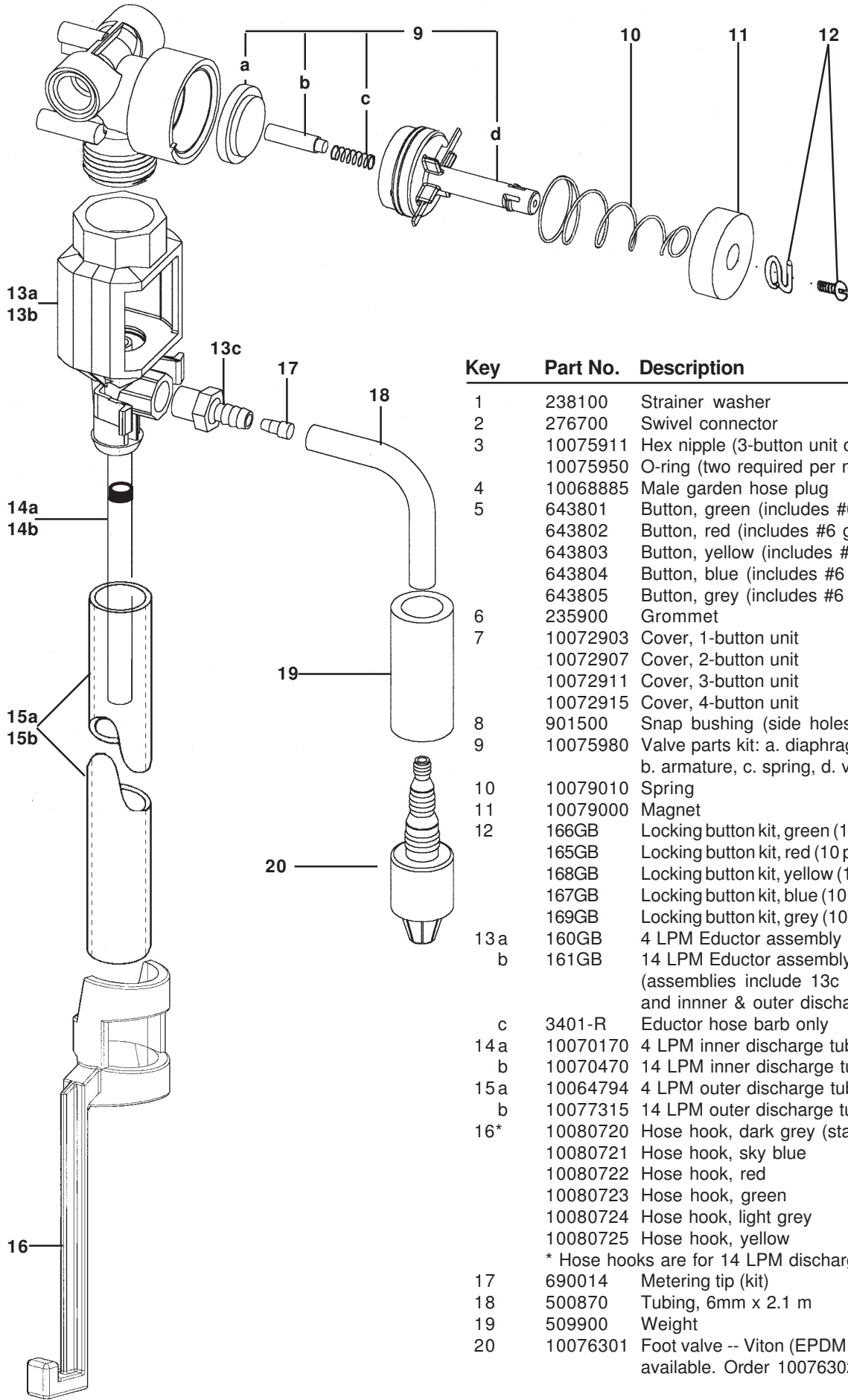

Key	Part No.	Description
1	238100	Strainer washer
2	276700	Swivel connector
3	10075911	Hex nipple (3-button unit only)
	10075950	O-ring (two required per nipple)
4	10068885	Male garden hose plug
5	643801	Button, green (includes #6 grommet)
	643802	Button, red (includes #6 grommet)
	643803	Button, yellow (includes #6 grommet)
	643804	Button, blue (includes #6 grommet)
	643805	Button, grey (includes #6 grommet)
6	235900	Grommet
7	10072903	Cover, 1-button unit
	10072907	Cover, 2-button unit
	10072911	Cover, 3-button unit
	10072915	Cover, 4-button unit
8	901500	Snap bushing (side holes)
9	10075980	Valve parts kit: a. diaphragm, b. armature, c. spring, d. valve bonnet
10	10079010	Spring
11	10079000	Magnet
12	166GB	Locking button kit, green (10 pack)
	165GB	Locking button kit, red (10 pack)
	168GB	Locking button kit, yellow (10 pack)
	167GB	Locking button kit, blue (10 pack)
	169GB	Locking button kit, grey (10 pack)
13 a	160GB	4 LPM Eductor assembly (2 per kit)
b	161GB	14 LPM Eductor assembly (2 per kit) (assemblies include 13c hose barb and inner & outer discharge tubes)
c	3401-R	Eductor hose barb only
14 a	10070170	4 LPM inner discharge tube
b	10070470	14 LPM inner discharge tube
15 a	10064794	4 LPM outer discharge tube (18cm)
b	10077315	14 LPM outer discharge tube (1.2 m)
16*	10080720	Hose hook, dark grey (standard)
	10080721	Hose hook, sky blue
	10080722	Hose hook, red
	10080723	Hose hook, green
	10080724	Hose hook, light grey
	10080725	Hose hook, yellow
	* Hose hooks are for 14 LPM discharge tubes	
17	690014	Metering tip (kit)
18	500870	Tubing, 6mm x 2.1 m
19	509900	Weight
20	10076301	Foot valve -- Viton (EPDM also available. Order 10076302.)

## TROUBLESHOOTING CHART:

Problem	Cause	Solution
1. No discharge	<ul style="list-style-type: none"> <li>a. No water</li> <li>b. Magnetic valve not functioning</li> <li>c. Excessive water pressure</li> <li>d. Eductor clogged</li> </ul>	<ul style="list-style-type: none"> <li>a. Open water supply</li> <li>b. Install valve parts kit</li> <li>c. Install regulator if flowing water pressure exceeds 4.3 Bar</li> <li>d. Clean* or replace</li> </ul>
2. No concentrate draw	<ul style="list-style-type: none"> <li>a. Clogged foot valve</li> <li>b. Metering tip or eductor has scale build-up</li> <li>c. Low water pressure</li> <li>d. Discharge tube and/or flooding ring not in place</li> <li>e. Concentrate container empty</li> <li>f. Inlet hose barb not screwed into eductor tightly</li> <li>g. Clogged water inlet strainer</li> </ul>	<ul style="list-style-type: none"> <li>a. Clean or replace</li> <li>b. Clean (descale)* or replace</li> <li>c. Minimum 1.76 Bar (with water running) required to operate unit properly</li> <li>d. Push tube firmly onto eductor discharge hose barb, or replace tube if it doesn't have a flooding ring</li> <li>e. Replace with full container</li> <li>f. Tighten, but do not overtighten</li> <li>g. Disconnect inlet water line and clean strainer</li> </ul>
3. Excess concentrate draw	<ul style="list-style-type: none"> <li>a. Metering tip not in place</li> </ul>	<ul style="list-style-type: none"> <li>a. Press correct tip firmly into barb on eductor</li> </ul>
4. Failure of unit to turn off	<ul style="list-style-type: none"> <li>a. Water valve parts dirty or defective</li> <li>b. Magnet doesn't fully return</li> <li>c. Push button stuck</li> <li>d. Excessive water pressure</li> </ul>	<ul style="list-style-type: none"> <li>a. Clean* or replace with valve parts kit</li> <li>b. Make sure magnet moves freely. Replace spring if short or weak</li> <li>c. Realign cabinet or clean grommet that button passes through (part no. 235900)</li> <li>d. Install regulator if pressure (with water flowing) exceeds 4.3 Bar</li> </ul>
5. Excess foaming in discharge	<ul style="list-style-type: none"> <li>a. Air leak in pick-up tube</li> <li>b. Inner discharge tube not in place</li> </ul>	<ul style="list-style-type: none"> <li>a. Put clamp on tube or replace tube if brittle</li> <li>b. Install inner discharge tube</li> </ul>
6. Water discharge from air vents of eductor	<ul style="list-style-type: none"> <li>a. Restricted discharge hose</li> <li>b. High water pressure</li> </ul>	<ul style="list-style-type: none"> <li>a. Be sure discharge hose is not immersed, kinked or elevated. Be sure there is no liquid in the discharge hose when beginning to operate dispenser</li> <li>b. Install pressure regulator if flowing water pressure exceeds 4.3 Bar</li> </ul>

\* In hard water areas, scale may form inside the discharge end of the eductor, as well as in other areas of the unit that are exposed to water. This scale may be removed by soaking the eductor in a descaling solution (deliming solution). To remove an eductor located in the cabinet, firmly grasp valve and unthread eductor. Replace in same manner. Alternatively, a scaled eductor can be cleaned (or kept from scaling) by drawing the descaling solution through the unit. Operate the unit with the suction tube in the descaling solution. Operate the unit until solution is drawn consistently, then flush the unit by drawing clear water through it for a minute. Replace concentrate container and put suction tube into concentrate.

