



AccuDose Series Proportioner

Package Contains:

1. Proportioner unit.
2. Supply tubing.
3. Foot valve assembly & weight for each eductor.
4. Discharge tube for each eductor.
5. Metering tip kit(s).
6. Mounting anchor kit.
7. Hook(s) for discharge tube(s) -- Models with 16 LPM eductors only.
8. Instruction sheet.

Installation and Operation:

1. Remove cabinet cover. Drill holes for the three wall anchors with a 7mm drill bit, using the cabinet back as a template for proper spacing of the mounting screws. Install mounting anchors, and then screws in top two anchors. Slide key holes in cabinet back over screw heads, tighten screws, then install bottom screw. Do not mount more than 1.8 meters above the bottom of the concentrate container, nor below the highest concentrate level (never mount concentrate container higher than the proportioner).
3. Select a metering tip (see next section), and insert into hose barb on eductor body. (Repeat for all eductors.)
4. Supply tube should reach from hose barb on eductor to bottom of the concentrate container. Cut supply tube provided to length required. Slide a ceramic weight over one end of tube and slide a foot valve into the same end of the tube. (Prepare a tube for each eductor.)
5. Slip other end of supply tube through an opening in either side of the cabinet and push over the hose barb/metering tip on the eductor. (Repeat for all eductors.)
6. Place foot valve ends of supply tubes into concentrate containers. **REMEMBER TO CHECK FOOT VALVE STRAINERS PERIODICALLY FOR CLOGGING: CLEAN IF NECESSARY.**
7. A short discharge tube is used with the 4 LPM eductor; minimum tube length is 20cm for correct operation. Longer tubes (1.2 m) are used with a 16 LPM eductor. Do not remove the flooding rings from inside the tubes. Slide end of tube with flooding ring over eductor discharge outlet. (Repeat for all eductors.) Hooks may be installed on longer tubes to allow discharge tube to hang from dispenser when not in use.
8. Replace cabinet cover. Push the sides in, behind the latch holes, to snap the cover in place. The two screws provided may be installed in the holes in the cabinet sides to prevent easy removal of cover.
9. Connect water supply hose of at least 13mm ID to water inlet swivel. (Minimum 1.76 Bar pressure, **with water running**, is required for correct operation.) Connect opposite end of hose to water supply. Turn water supply on.
10. Purge air from the system by pressing the buttons briefly.
11. Push button to start flow of desired water/concentrate solution, and hold until supply tube is primed (filled). Then push the button whenever dispensing is required, and release button to stop flow of solution. If you wish to be able to lock the button in the "on" position: clip or bend the two tabs behind the lower front portion of the button (see diagram). This allows the button to be fully depressed and allows it to latch in the "on" position. **TO UNLOCK, PULL THE BUTTON OUT.**

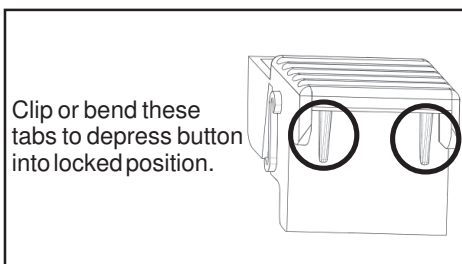

Metering Tip Selection:

The final concentration of the dispensed solution is related to both the size of the metering tip opening and the viscosity of the liquid being siphoned. For water-thin products, the chart at right can be used as a guideline. If product is noticeably thicker than water, consult the Measurement of Concentration Procedure below to achieve your desired water-to-product ratio. Because dilution can vary with water temperature and pressure, actual dilution achieved can only be ascertained by using the Measurement of Concentration Procedure. The clear, undrilled tip is provided to permit drilling to size not listed should you need a dilution ratio that falls between standard tip sizes.

NOTE: A 4 LPM eductor is grey; a 16 LPM eductor is yellow. Refer to parts diagram if unfamiliar with names of system components.

Measurement of Concentration:

You can determine the dispensed water-to-product ratio for any metering tip size and product viscosity. All that is required is to operate the primed dispenser for a minute or so and note two things: the amount of dispensed solution, and the amount of concentrate used in preparation of the solution dispensed. The water-to-product ratio is then calculated as follows:

$$\text{Dilution Ratio (X:1) where X} = \frac{\text{Amount of Mixed Solution} - \text{Amount of Concentrate Drawn}}{\text{Amount of Concentrate Drawn}}$$

Dilution Ratio, then, equals X parts water to one part concentrate (X:1). If the test does not yield the desired ratio, choose a different tip and repeat the test. Alternative methods to this test are 1) pH (using litmus paper), and 2) titration. Contact your concentrate supplier for further information on these alternative methods and the materials required to perform them.

| APPROXIMATE DILUTIONS AT 2.86 BAR FOR WATER-THIN PRODUCTS (1.0 CP) | | | | |
|-----------------------------------------------------------------------|--------------|-------------------|--------------------------|--------|
| Tip Colour | Orifice Size | Std. Drill Number | Ratio (per Eductor Flow) | |
| | | | 4 LPM | 16 LPM |
| No Tip | .187 | (3/16) | 2:1 | 3:1 |
| Grey | .128 | (30) | 2:1 | 3:1 |
| Black | .098 | (40) | 2:1 | 4:1 |
| Beige | .070 | (50) | 3:1 | 8:1 |
| Red | .052 | (55) | 4:1 | 14:1 |
| White | .043 | (57) | 5:1 | 20:1 |
| Blue | .040 | (60) | 6:1 | 24:1 |
| Tan | .035 | (65) | 8:1 | 30:1 |
| Green | .028 | (70) | 12:1 | 45:1 |
| Orange | .025 | (72) | 16:1 | 56:1 |
| Brown | .023 | (74) | 18:1 | 64:1 |
| Yellow | .020 | (76) | 24:1 | 90:1 |
| Aqua | .018 | (77) | 32:1 | 128:1 |
| Purple | .014 | (79) | 45:1 | 180:1 |
| Pink | .010 | (87) | 128:1 | 350:1 |

**AccuDose Parts Diagram:
3-button unit illustrated**

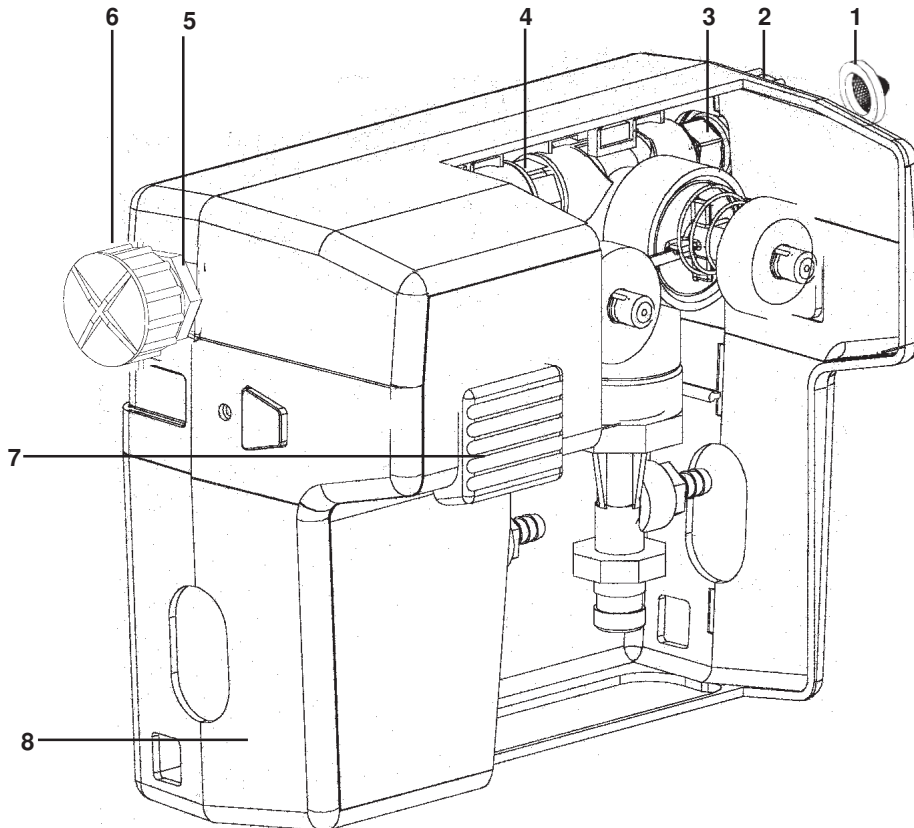

AccuDose Parts Diagram/List:

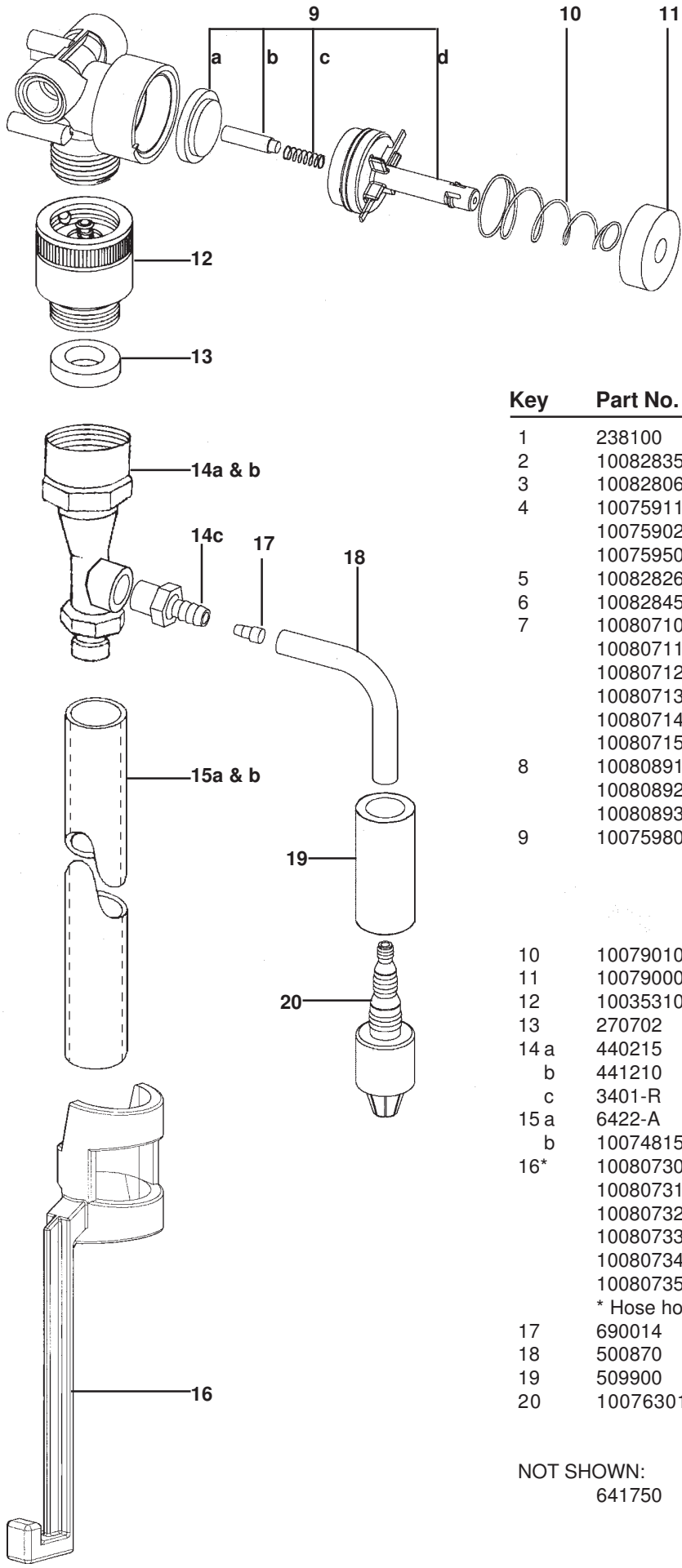

| Key | Part No. | Description |
|------|---------------------------------------------|------------------------------------------------------------|
| 1 | 238100 | Strainer washer |
| 2 | 10082835 | Swivel collar (molded) |
| 3 | 10082806 | Swivel stem (molded) |
| 4 | 10075911 | Hex nipple (3-button unit only) |
| | 10075902 | Nipple (2-button unit only) |
| | 10075950 | O-ring (two required per nipple) |
| 5 | 10082826 | Connector fitting |
| 6 | 10082845 | Connector fitting cap |
| 7 | 10080710 | Button, dark grey (standard) |
| | 10080711 | Button, sky blue |
| | 10080712 | Button, red |
| | 10080713 | Button, green |
| | 10080714 | Button, light grey |
| | 10080715 | Button, yellow |
| 8 | 10080891 | Cabinet set, 1-button unit |
| | 10080892 | Cabinet set, 2-button unit |
| | 10080893 | Cabinet set, 3-button unit (shown) |
| 9 | 10075980 | Valve parts kit |
| | a. | diaphragm |
| | b. | armature |
| | c. | spring |
| | d. | valve bonnet |
| 10 | 10079010 | Spring |
| 11 | 10079000 | Magnet |
| 12 | 10035310 | Siphon breaker |
| 13 | 270702 | Washer |
| 14 a | 440215 | 4 LPM Eductor assembly |
| b | 441210 | 16 LPM Eductor assembly |
| c | 3401-R | Eductor hose barb only |
| 15 a | 6422-A | 4 LPM discharge tube (18cm) |
| b | 10074815 | 16 LPM discharge tube (1.2 m) |
| 16* | 10080730 | Hose hook, dark grey (standard) |
| | 10080731 | Hose hook, sky blue |
| | 10080732 | Hose hook, red |
| | 10080733 | Hose hook, green |
| | 10080734 | Hose hook, light grey |
| | 10080735 | Hose hook, yellow |
| | * Hose hooks are for 16 LPM discharge tubes | |
| 17 | 690014 | Metering tip (kit) |
| 18 | 500870 | Tubing, 6mm x 2.1 m |
| 19 | 509900 | Weight |
| 20 | 10076301 | Foot valve -- Viton (EPDM also available. Order 10076302.) |

NOT SHOWN:
641750 Security screws (for cabinet sides)

Troubleshooting Chart:

| Problem | Cause | Solution |
|----------------------------------------------|---------------------------------------------------------------------------------------------------------------------------------------------------------------------------------------------------------------------------------------------------------------------------------------------------------------------|--------------------------------------------------------------------------------------------------------------------------------------------------------------------------------------------------------------------------------------------------------------------------------------------------------------------------------------------------------------------------------------------|
| 1. No discharge | a. No water b. Magnetic valve not functioning c. Excessive water pressure d. Eductor clogged | a. Open water supply b. Install valve parts kit c. Install regulator if water pressure exceeds 4.3 Bar (flowing) d. Clean* or replace |
| 2. No concentrate draw | a. Clogged foot valve b. Metering tip or eductor has scale build-up c. Low water pressure d. Discharge tube(s) not in place or flooding ring missing from inner discharge tube e. Concentrate container empty f. Inlet hose barb not screwed into eductor tightly g. Clogged water inlet strainer | a. Clean or replace b. Clean (descale)* or replace c. Minimum 1.43 Bar (with water running) required to operate unit properly d. Push tube firmly onto eductor discharge hose barb; be sure inner discharge tube is installed and has flooding ring. e. Replace with full container f. Tighten, but do not overtighten g. Disconnect inlet water line and clean strainer |
| 3. Excess concentrate draw | a. Metering tip not in place b. Chemical above eductor | a. Press correct tip firmly into barb on eductor b. Place concentrate below the eductor |
| 4. Failure of unit to turn off | a. Water valve parts dirty or defective b. Magnet doesn't fully return c. Push button stuck | a. Clean* or replace with valve parts kit b. Make sure magnet moves freely. c. Remove button and clean cabinet/button to remove any dirt lodged in slide recess |
| 5. Excess foaming in discharge | a. Air leak in pick-up tube b. Inner discharge tube not in place | a. Put clamp on tube or replace tube if brittle b. Install inner discharge tube |
| 6. Water discharge from air vents on eductor | a. Restricted discharge hose b. High water pressure | a. Be sure discharge tube is not immersed, kinked or elevated. Be sure there is no liquid in the discharge tube when beginning to operate dispenser b. Install pressure regulator if flowing water pressure exceeds 4.3 Bar (flowing) |

* In hard water areas, scale may form inside the discharge end of the eductor, as well as in other areas of the unit that are exposed to water. This scale may be removed by soaking the eductor in a descaling solution (deliming solution). To remove an eductor located in the cabinet, firmly grasp water valve and unthread eductor. Replace in same manner. Alternatively, a scaled eductor can be cleaned (or kept from scaling) by drawing the descaling solution through the unit. Operate the unit with the suction tube in the descaling solution. Operate the unit until solution is drawn consistently, then flush the unit by drawing clear water through it for a minute. Replace concentrate container and put suction tube into concentrate.

