



NOVA CONTROLS
LEADING THE WAY

A **Hydro** Systems Company

Flush Manifold

FOR LIQUID LAUNDRY SUPPLY SYSTEMS

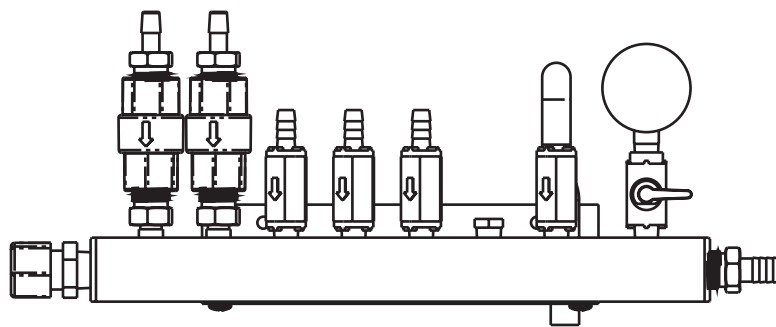
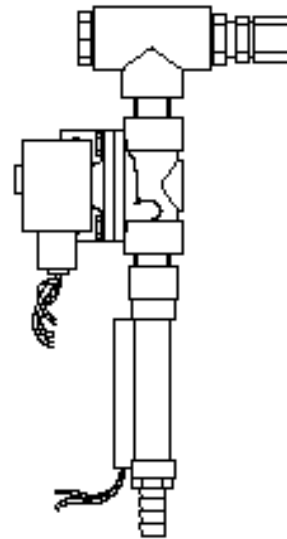
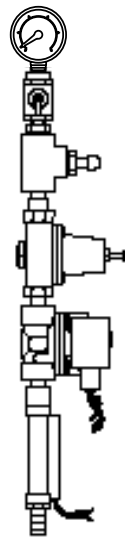

Reference Manual

FM-500 HF Series

Figure 1.0.a Description, Standard Flush Valve

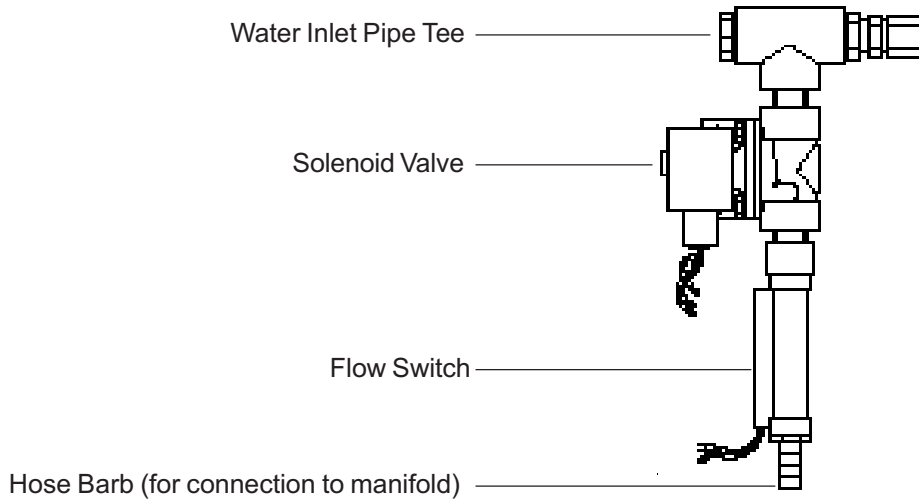
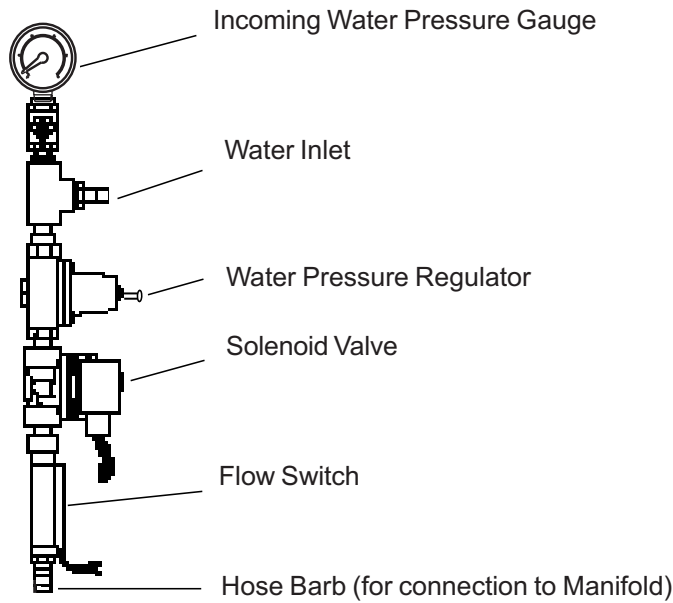

Figure 1.0.b Description, Industrial Flush Valve



1.0 DESCRIPTION

DESCRIPTION

The FM-500 HF series Flush Manifold is a universal design compatible with our LM and LL series liquid laundry dispensing systems.

The FM-500 HF series Flush Manifold is comprised of two major components, a Manifold Assembly and a choice of two different Flush Valve assemblies.

The Standard Flush Valve Assembly consists of a pipe tee/water inlet fitting (1/2" tube) at the top, an ASCO brass solenoid valve, a flow switch (for connection to our LM series Flush Interface Kit), and a 1/2" hose barb at the bottom for hose connection to the Manifold Assembly.

The Industrial Flush Valve Assembly consists of a single water inlet (1/2" hose barb, no pipe tee), a water pressure gauge with an "open to read" water valve on top, a water pressure regulator, an ASCO brass solenoid valve, a flow switch (for connection to our LM series Flush Interface Kit), with a 1/2" hose barb at the bottom for hose connection to the Manifold Assembly.

The **Manifold Assembly** is a horizontal pipe with check valves, a vacuum relief valve, and a pressure gauge with an "open to read" water valve, all mounted on the top. A 1/2" hose barb for hose connection to the Flush Valve Assembly is on one end and a 5/8" tube compression fitting for polyflow discharge tubing connection is on the other end.

The modular design allows more installation flexibility with liquid laundry chemical dispensing systems. Both the Manifold and Valve Assembly Brackets may be reversed to allow installation for flow from left to right.

1.1 Theory of Operation

The FM-500 HF series Flush Manifold transfers liquid laundry chemical products from the dispensing system to the washer using water flow (or flush) via a single discharge tube. The dispenser pumps into the manifold via the check valves. The flush valve controls water flow through the manifold, which in turn transfers product to the washer. The vacuum relief valve allows any standing water in the system to drain into the washer without drawing a siphon on the product pumps. A manifold pressure gauge is present to measure and set system pressure while flushing. The flush valve may be controlled by our LM-100 series dispenser controller (this limits the LM-100 dispenser to five pumps) with our LM-100/LL-6000 Flush Interface Kit (Nova Controls P/N 13-04794-05).

Figure 1.0.c Description, Manifold

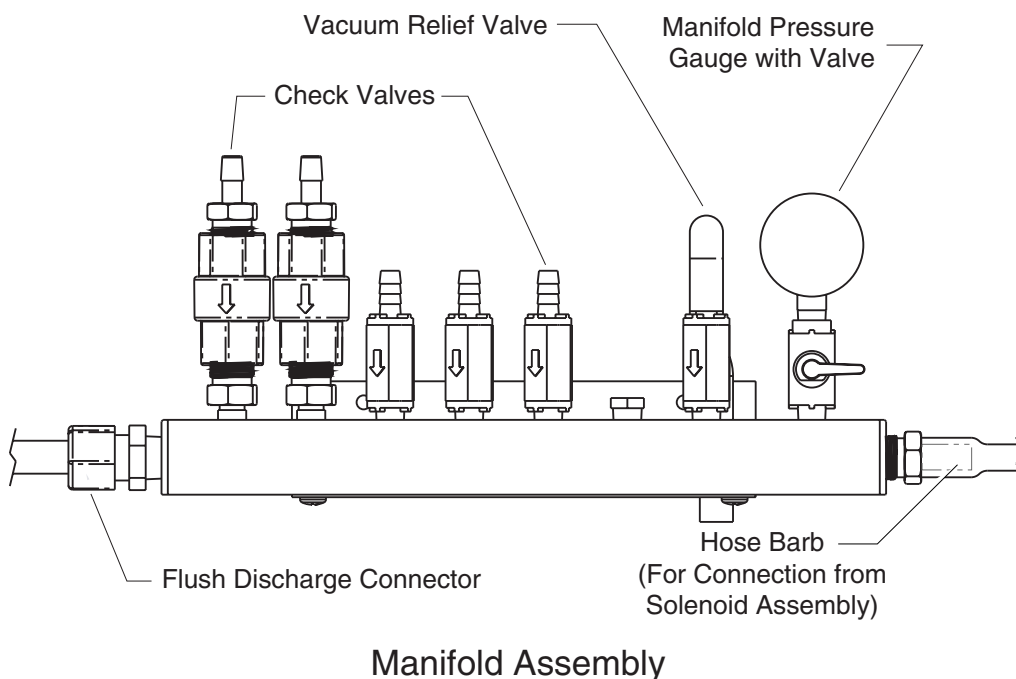

2.0 INSTALLATION

DESCRIPTION

INSTALLATION

SYSTEM SETUP

SPARE PARTS LISTING

SPECIFICATIONS

The laundry dispensing system should be installed prior to the Flush Manifold. A method of driving the flush valve needs to be determined on the initial site survey. We strongly recommend using the flush valve drive capabilities of our controllers, with our safety interlocks in place for the most reliable, and safest, operation.

CAUTION: A locally approved backflow prevention device—not provided—is required for safe and legal operation. A water pressure regulator is required for use with our standard Flush Valve Assembly. This regulator may be shared by a number of flush valves, limited by the water flow and pressure at the site.

2.0 Manifold Assembly Installation

2.1.1 Position the Manifold Assembly on the wall below the dispenser Pump Module. Reverse the Manifold mounting bracket position when flow from left to right is desired.

NOTE: Allow clearance for the Pump Module cabinet to open.

2.1.2 Using a pencil, outline each of the two holes on the Manifold mounting bracket.

2.1.3 Drill the outlined holes with a 1/4" masonry bit and place a wall anchor, supplied, into each hole.

2.1.4 Secure the Manifold assembly to the wall anchors with supplied screws.

2.2 Pump Tube Connection

Use short lengths of 3/8" ID tubing and appropriate size hose barbs, supplied in the installation kit, to connect the discharge side of the dispenser pumps to the Check Valve hose barbs.

2.2.1 Connect short lengths of the 3/8" ID flexible tubing to the dispenser pump tubes with the provided hose barbs. Secure with hose clamps or tie wraps to ensure a leak free assembly.

2.2.2 Trim the 3/8" ID tubes to fit—do not connect to the check valves yet.

2.2.3 Perform “Calibrate Pumps” on the controller, capturing product at the ends of the tubing.

2.2.4 Connect tubes to the hose barbs on the check valves. Secure with hose clamps or tie wraps to ensure a leak free assembly.

2.3 Flush Valve Installation

2.3.1 Position the Flush Valve Assembly on the wall beside the dispenser Pump Module. Reverse the Flush Valve mounting bracket position when flow from left to right is desired.

2.3.2 Using a pencil, outline each of the two holes on the solenoid mounting bracket.

2.3.3 Drill the outlined holes with a 1/4" masonry bit and place a wall anchor, supplied, into each hole.

2.3.4 Secure the flush valve assembly to the wall anchors with supplied screws.

2.4 Water Supply Connection, Standard Flush Valve

Use 1/2" polyflow tubing for water supply connection from the water pressure regulator and back flow prevention device—not provided. A plugged female 1/2" NPT pipe connection to connect plumbing fittings for multiple manifolds is available on the water supply pipe tee fitting.

WARNING: An approved Back Flow Prevention Device and Water Pressure Regulator (set for a reading of no more than 10 psi on the manifold pressure gauge while flushing) MUST be used between the Flush Valve and water source.

2.4.1 Measure the distance from the water pressure regulator—not provided—to the Flush Manifold water supply connection.

2.4.2 Cut a piece 1/2" polyflow tubing—not provided—to the desired length.

2.4.3 Connect the tubing to the output of the water pressure regulator.

2.4.4 Connect the opposite end of tubing to the water supply connection 1/2" compression fitting.

2.4.5 Affix provided plumbing caution label in area of Flush System.

2.5 Water Supply Connection, Industrial Flush Valve

Use 1/2" ID hose for water supply connection from the back flow prevention device—not provided.

WARNING: An approved Back Flow Prevention Device **MUST** be used between the Flush Valve and water source.

- 2.5.1 Measure the distance from the water source to the Flush Valve water supply connection.
- 2.5.2 Cut a piece 1/2" ID hose—not provided—to the desired length.
- 2.5.3 Connect the tubing to the water source.
- 2.5.4 Connect opposite end of tubing to water supply connection 1/2" hose barb and secure with a hose clamp.
- 2.5.5 Affix provided plumbing caution label in area of Flush System.

2.6 Flush Discharge Connection

Use a single 5/8" polyflow flush outlet tube—not provided—to deliver product to the laundry machine.

IMPORTANT: The flush discharge tubing **MUST NOT** exceed 50'.

- 2.6.1 Measure the distance from the Flush Manifold to the laundry machine.
- 2.6.2 Cut a piece 5/8" polyflow tubing—not provided—to the desired length.
- 2.6.3 Connect the tubing to the Flush Manifold discharge 5/8" compression fitting.
- 2.6.4 Route the tubing to the laundry machine and secure at the product injection port.

NOTE: Secure the flush discharge tube at the laundry machine so that the water flush will rinse the product injection area. This will help ensure against chemical attack to the laundry machine. Secure all tubing for a neat and clean installation.

2.7 Flush Valve to Manifold Connection

- 2.7.1 Measure distance from Flush Valve to the Manifold and trim the provided 1/2" ID Hose to fit.
- 2.7.2 Connect the Hose to the hose barb at the bottom of the Solenoid Assembly and the hose barb on the right side of the Manifold.
- 2.7.3 Secure both ends of the hose with provided ratchet clamps.

2.8 Hard Copper Plumbing

If the water supply connection must be copper tubing, you will be responsible for the correct pipe fittings and connectors to complete the installation. Always use an approved Back Flow Prevention Device and Water Pressure Regulator. Plastic compression fittings can be removed and replaced with the appropriate fittings to accommodate copper tubing. Use RTV sealant on the plastic plumbing threads and **DO NOT** solder to fittings that are threaded into plastic. Water supply lines require a minimum 1/2" tube.

2.9 Electrical Connections

The FM-500 HF series flush valve may be equipped with a choice of AC voltage solenoid coils for flush activation. Confirm that your coil voltage is correct for your application. With LM-100 series and LL-6000 series dispensers, the solenoid coil voltage needs to match the pump motor voltage.

WARNING: **DO NOT** connect any voltage other than what is called out on the solenoid coil. A wire conduit is required for solenoid coil wiring when using any coil voltage over 24 volts, AC. The bottom of the solenoid coil is threaded to accommodate conduit.

The solenoid valve has two wires, labeled "Solenoid Coil", with 1/4" female push on connectors for connection to the flush output wiring harness or to the Flush Interface Kit flush output wires. A green ground wire is also present and should be run to the dispenser cabinet. The flow switch has two wires, labeled "Flow Switch", with 1/4" male push on connectors. These wires connect to the flush wiring harness blue wires (to pressure switch input on the circuit board) or to our Flush Interface Kit safety interlock blue wires. These wires are low voltage and may be run exposed in most areas.

- 2.9.1 Connect the solenoid coil power wires to the Solenoid coil wires from the pumpstand, or to the Flush Interface kit solenoid coil wires.
- 2.9.2 Connect the Flow Switch wires to the Pressure Switch input on the pumpstand, or to the Flush Interface kit flow switch wires.

DESCRIPTION

INSTALLATION

SYSTEM SETUP

SPARE PARTS LISTING

SPECIFICATIONS

3.0 SYSTEM SETUP

DESCRIPTION

INSTALLATION

SYSTEM SETUP

SPARE PARTS LISTING

SPECIFICATIONS

Check entire dispensing system for correct electrical and plumbing connections. After pump calibration and formula programming, test run the system to determine appropriate flush time setting to transfer all product to the washer. Input new flush time in program mode of the controller. Also, reconfirm that the washer calls for product at appropriate times and the dispensing system pumps when it should. Flush system pressures should be measured at the manifold pressure gauge by opening the gauge protection valve while flushing. Adjust the water pressure regulator for no more than a 10 psi reading on the manifold gauge while flushing. Inspect flush system for water leaks, and test run a load of linen.

CAUTION: Turn off gauge valve when done reading manifold pressure to prevent water hammer damage to gauge.

NOTE: To manually open flush valve, to purge or clean water lines and manifold, press up or down arrow on the Orion E series controller to access a manual flush control.

OPERATING WARNING: Never mix incompatible chemicals in the flush manifold. Mixing chemicals can cause personal injury or mechanical damage to the unit.

4.0 SPARE PARTS LISTING

Figure 4.0.a
Industrial Flush Valve

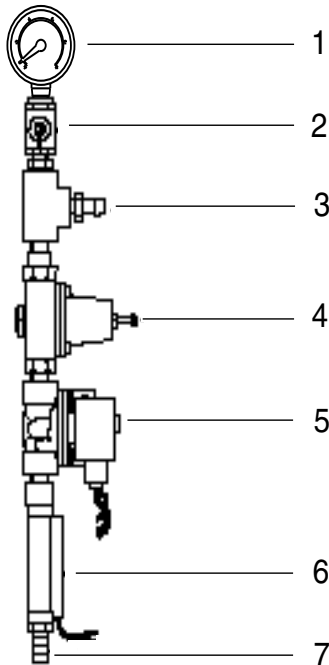

Figure 4.0.b
Standard Flush Valve

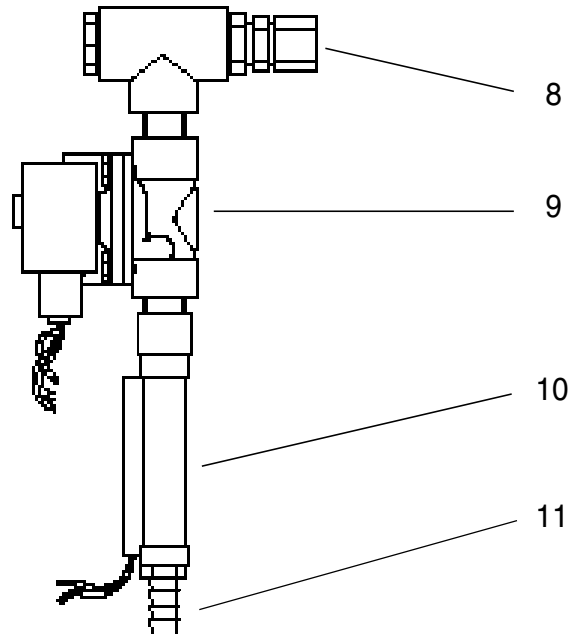
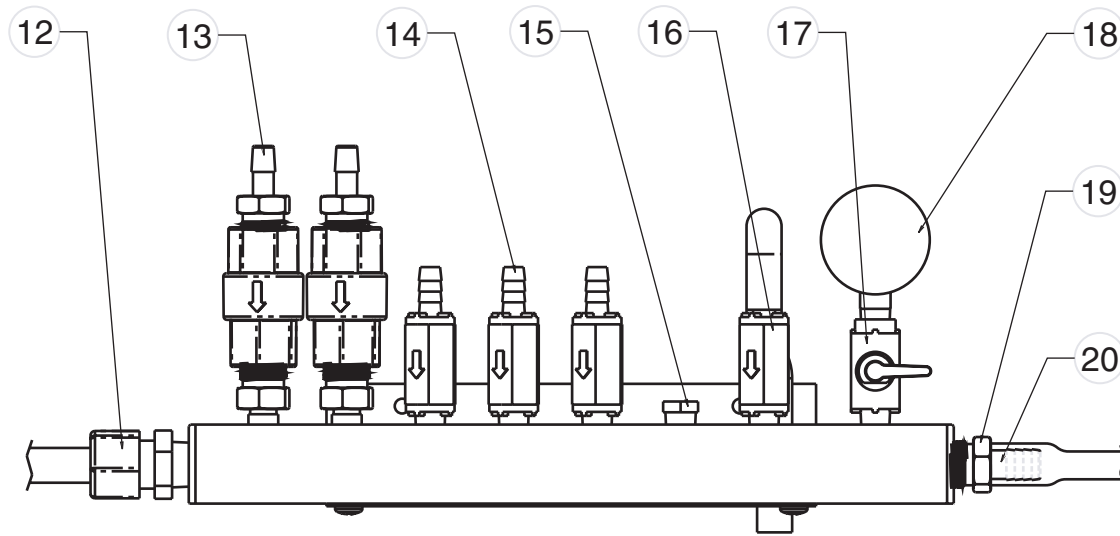

Figure 4.0.c Manifold



DESCRIPTION

INSTALLATION

SYSTEM SETUP

SPARE PARTS LISTING

SPECIFICATIONS

ITEM DESCRIPTION

PART NUMBER

Industrial Flush Valve, Specify Coil Voltage	00-04816-xx
1 Pressure Gauge	49-04796-00
2 Valve	41-04797-00
3 Hose Barb, 1/2" Tube	41-04469-00
4 Pressure Regulator	49-04802-00
5 Solenoid Valve, Specify Coil Voltage	49-04803-xx
6 Flow Switch	56-04470-00
7 1/2" Hose Barb Fitting, For Flow Switch	41-04478-00
Standard Flush Valve, Specify Coil Voltage	00-04815-xx
8 Compression Fitting, 1/2" Tube	41-03561-881
9 Solenoid Valve, Specify Coil Voltage	49-04803-xx
10 Flow Switch	56-04470-00
11 1/2" Hose Barb Fitting, For Flow Switch	41-04478-00
Manifold Assembly	01-07551-05
12 5/8" Flush Discharge Compression Fitting	41-03561-1081
13 Check Valve Assy, Hi Flow	03-07546-00
14 Check Valve, 3/8" Hose Barb	41-04207-46
15 Vacuum Relief Valve	49-04831-00
16 Hole Plug, CPVC, 1/4" Male	41-04468-00
17 Valve	41-04797-00
18 Pressure Gauge	49-04808-00
19 Ratchet Clamp	41-04474-00
20 1/2" Hose Barb	41-04996-01
Flush Valve Mounting Kit	13-04814-00
Manifold Accy. Kit, 5 Pump	13-04794-05
Hose Barb, 3/8" X 5/16"	41-05112-00
Hose Barb, 3/8" X 3/8"	37-07157-0606

NOTE: Specify "Metric" when ordering to obtain metric equivalent plumbing fittings.

5.0 SPECIFICATIONS FM-500 HF

DESCRIPTION

INSTALLATION

SYSTEM SETUP

SPARE PARTS LISTING

SPECIFICATIONS

5.1 Unit Specifications

Size, Manifold: 17" wide X 6.25" high X 2.5" deep (43.2cm. W X 15.9cm. H X 6.4cm. D)
Size, Solenoid Assembly: 6.25" wide X 10.25" high X 3.0" deep (15.9cm. W X 26.0cm. H X 7.6cm. D)
Weight, Manifold Assembly: 2.6 lbs. (1.1 kg.)
Weight, Solenoid Assembly: 2.1 lbs. (0.9 kg.)
Power (Specify Coil Voltage): 24, 110, 208, 240 volts, AC, 50 or 60 hertz

5.1.a Water Specifications

Maximum Pressure: No more than 10 PSI at manifold gauge, when flushing.
Maximum Temperature: 120° F (48.9° C)
Minimum Temperature: 40° F (4.4° C)

NOTE: All specifications subject to change without notice.

5.2 Ordering Information

A manifold and choice of flush valves need to be ordered together to make up a FM-500 HF series flush system.

Specify "Metric" when metric equivalent plumbing fittings are desired.

Flush Manifold 01-07551-05
Standard Flush Valve, Specify Coil Voltage 00-04815-XX
Industrial Flush Valve, Specify Coil Voltage 00-04816-XX

5.2.a Options

LM-100/LL-6000 Flush Interface Kit 13-04830-00
Orion EX Controller 01-04750-02
Orion EXF Controller 01-04750-03

5.3 Limited Warranty

SELLER warrants solely to BUYER the Products will be free from defects in material and workmanship under normal use and service for a period of one year from the date of completion of manufacture. This limited warranty does not apply to (a) hoses; (b) and products that have a normal life shorter than one year; or (c) failure in performance or damage caused by chemicals, abrasive materials, corrosion, lightning, improper voltage supply, physical abuse, mishandling or misapplication. In the event the Products are altered or repaired by BUYER without SELLER'S prior written approval, all warranties will be void.

NO OTHER WARRANTY, ORAL, EXPRESS OR IMPLIED, INCLUDING ANY WARRANTY OF MERCHANTABILITY OR FITNESS FOR ANY PARTICULAR PURPOSE, IS MADE FOR THESE PRODUCTS, AND ALL OTHER WARRANTIES ARE HEREBY EXPRESSLY EXCLUDED.

SELLER'S sole obligation under this warranty will be, at SELLER'S option, to repair or replace F.O.B. SELLER'S facility in Watsonville, California any Products found to be other than as warranted.

5.4 Limitation of Liability

Seller's warranty obligations and buyers remedies are solely and exclusively as stated herein. Seller shall have no other liability, direct or indirect, of any kind, including liability for special, incidental, or consequential damages or for any other claims for damage or loss resulting from any cause whatsoever, whether based on negligence, strict liability, breach of contract or breach of warranty.

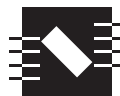

NOVA CONTROLS
LEADING THE WAY

A **Hydro** Systems Company

225 WESTRIDGE DRIVE
WATSONVILLE
CALIFORNIA
95076-4168 U.S.A.

TEL 831.786.1470
FAX 831.786.1650