



MaxiMizer II Proportioning System

Package Contains:

1. Proportioner unit.
2. Supply tube(s).
3. Foot valve(s) and weight(s).
4. Discharge tube(s).
5. Metering tip kit(s).
6. Mounting anchor kit.
7. Drip tray(s) for 4 LPM eductor(s) only.
8. Instruction sheet.

Installation and Operation:

(Repeat steps as necessary for each eductor the unit contains.)

1. Unlock the front door panel and open it.
2. To mount the unit to a wall, drill mounting holes and insert the plastic anchors provided into the holes. Use the screws provided to secure the unit to the wall.
3. Select a metering tip (see next section) and insert the tip into the eductor hose barb.
4. Connect a long, flexible discharge tube to the bottom of any 16 LPM (yellow) eductor, applying the end opposite the hook. Slide the hose out the bottom of the unit, through the holes provided. The hook allows the discharge tube to hang neatly when not in use. Make sure all discharge tubes are fully engaged onto the eductors.
5. Connect water supply hose of at least 13mm ID to water inlet swivel at right side of manifold. (Minimum 1.76 Bar pressure, with water running, is required for correct operation.) Push hose out of the side of the cabinet, through the hole provided, and attach the hose to the water supply source. Turn water supply on. If needed, the front panel can be removed by loosening the screws inside the bottom edge and then lifting the front off.
6. Install the suction tube as follows:
 - Slide a ceramic weight over one end of the piece of tubing.
 - Push the hose barb end of a foot valve into one end of the open tube.
 - Slide the weight down to the foot valve.
 - Place foot valve end of suction tube into the concentrate container and put container into proportioner cabinet.
 - Push the other (open) end of the suction tube assembly over the hose barb/metering tip on the eductor.
 - REMEMBER TO CHECK FOOT VALVE STRAINER FOR CLOGGING PERIODICALLY. CLEAN IF NECESSARY.
7. Close front door panel and lock. If dispenser has any 4 LPM eductors, make sure a drip tray is in its place at the bottom of the shelf, below concentrate container, for all 4 LPM stations.
8. Write product name on one of the labels supplied and apply the label under the button to correspond to the product that will be dispensed by depressing that button, and the type of container the solution will be dispensed into.
9. Push button to start flow of desired water/concentrate solution, and hold until solution starts to be discharged. (Make sure there is a bottle or other receptacle under the discharge tube.) Prime each of the supply tubes in this way. Then push the button whenever dispensing is desired, and release button to stop flow of solution. Buttons may be converted to twist-to-latch locking buttons by installing the latch spring provided (see parts diagram for placement). This allows continuous dispensing without holding button.

Metering Tip Selection:

The final concentration of the dispensed liquid is related to both the size of the metering tip opening and the viscosity of the liquid being siphoned. If product viscosity is noticeably greater than that of water, consult the procedure for Measurement of Concentration on the next page to achieve your desired water-to-product ratio. For water-thin products, use the chart on the next page as a **guideline**. Because such factors as inlet water pressure and temperature can affect dilution ratios, the figures listed on the chart are only approximate. Test the actual dilution you are achieving using the Measurement of Concentration procedure for best results. Use the undrilled, clear tip for drilling a size not listed.

Measurement of Concentration:

You can determine the dispensed water-to-product ratio for any metering tip and product viscosity. Simply operate the primed dispenser for a minute or so and note two things: the amount of dispensed solution, and the amount of concentrate used in preparation of the solution dispensed. The water-to-product ratio is then calculated as follows:

$$\text{Dilution Ratio (X:1) where X} = \frac{\text{Amount of Mixed Solution} - \text{Amount of Concentrate Drawn}}{\text{Amount of Concentrate Drawn}}$$

Dilution Ratio, then, equals X parts water to one part concentrate (X:1). If the test does not yield the desired ratio, choose a different tip and repeat the test. Alternative methods to this test are 1) pH (using litmus paper), and 2) titration. Contact your concentrate supplier for further information on these alternative methods and the materials required to perform them.

APPROXIMATE DILUTIONS AT 2.86 BAR FOR WATER-THIN PRODUCTS (1.0 CP)				
Tip Colour	Orifice Size	Std. Drill Number	Ratio (per Eductor Flow)	
			4 LPM	16 LPM
No Tip	.187	(3/16)	2:1	3:1
Grey	.128	(30)	2:1	3:1
Black	.098	(40)	2:1	4:1
Beige	.070	(50)	3:1	8:1
Red	.052	(55)	4:1	14:1
White	.043	(57)	5:1	20:1
Blue	.040	(60)	6:1	24:1
Tan	.035	(65)	8:1	30:1
Green	.028	(70)	12:1	45:1
Orange	.025	(72)	16:1	56:1
Brown	.023	(74)	18:1	64:1
Yellow	.020	(76)	24:1	90:1
Aqua	.018	(77)	32:1	128:1
Purple	.014	(79)	45:1	180:1
Pink	.010	(87)	128:1	350:1

MaxiMizer II Parts Diagrams & List

4-button manifold shown
(3-button similar; see 1-button manifold for fittings on left
side of 2-button manifold)

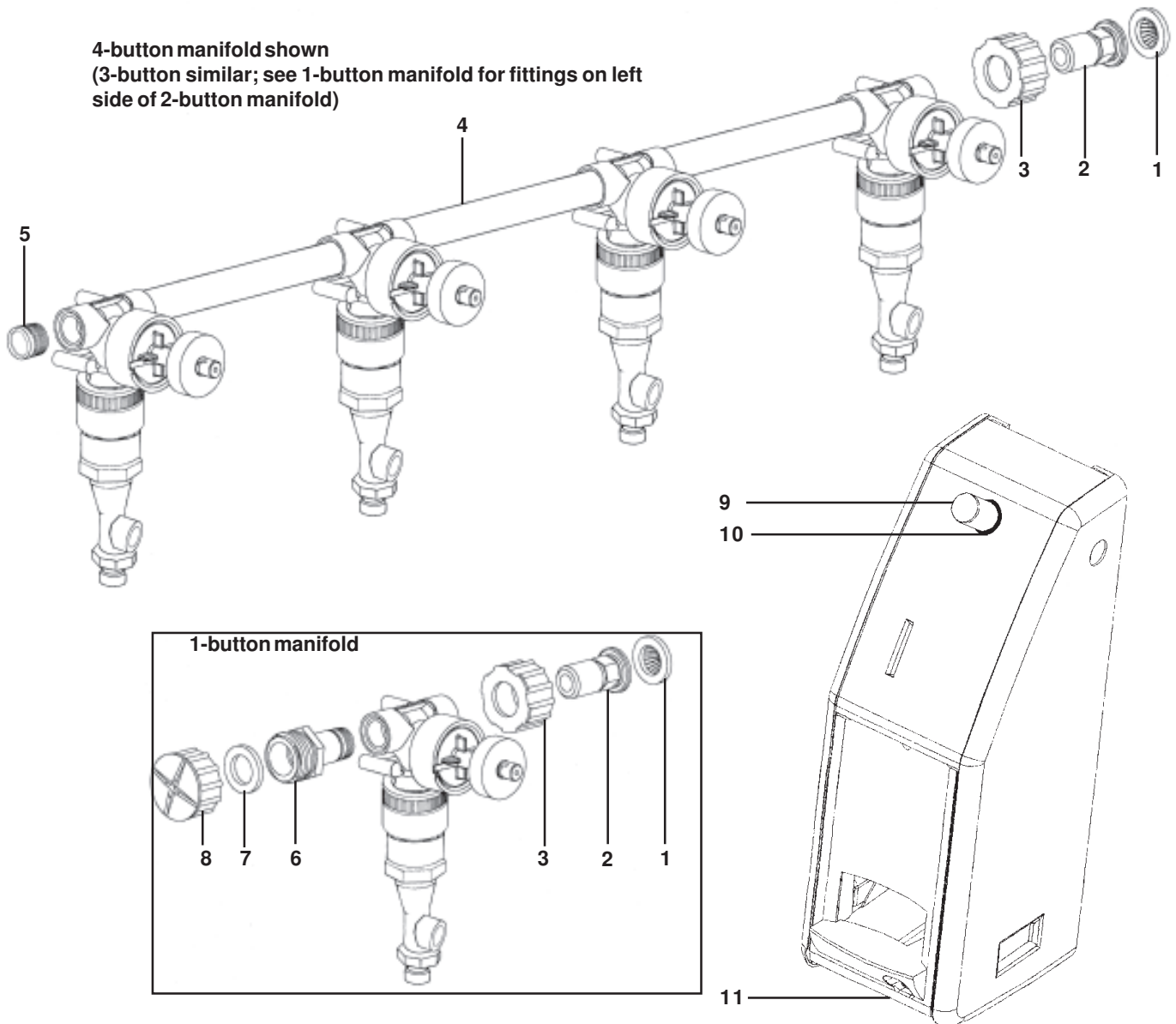

MaxiMizer II Parts Diagrams/List

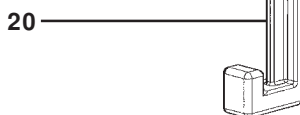
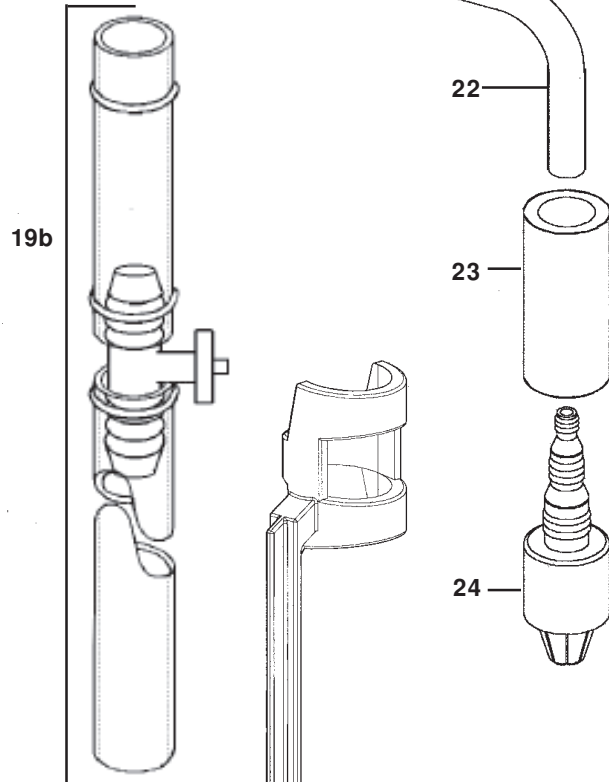
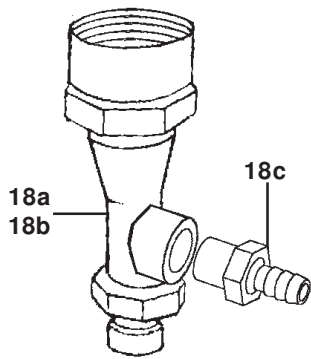
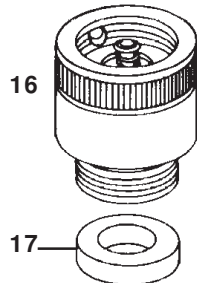
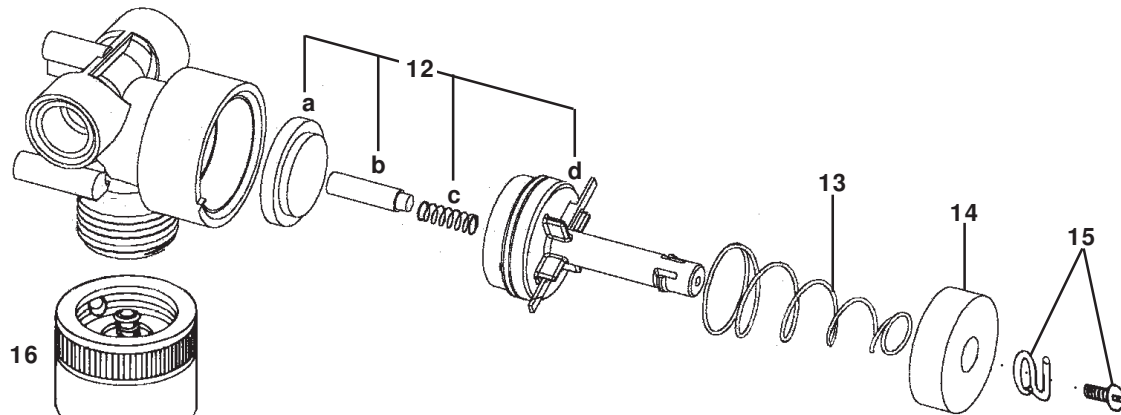

Key	Part No.	Description
1	238100	Strainer washer
2	10082806	Swivel stem
3	10082835	Hose swivel collar
4	10075901	Nipple (requires 2 O-rings 10075950)
5	10075925	Pipe plug
6	10082826	Male hose fitting (plastic)
7	10069260	Washer
8	10082845	Plastic cap
9	10077480	Button, dark grey
	10077481	Button, blue
	10077482	Button, red
	10077483	Button, green
	10077484	Button, yellow
	10077485	Button, light grey
	10077420*	Button, dark grey locking
	10077421*	Button, blue locking
	10077422*	Button, red locking
	10077423*	Button, green locking
	10077424*	Button, yellow locking
	10077425*	Button, light grey locking
10	10068810	Grommet (included with button kits)
11	10075160	Drip Tray (4 LPM stations only)
12	10075980	Valve parts kit: a. diaphragm, b. armature, c. spring, d. valve bonnet
13	10079010	Spring
14	10079000	Magnet
15	10068835	Locking button kit (allows locking flow "on")
16	10035310	Siphon breaker
17	10069260	Washer
18 a	441210	16 LPM Eductor assembly (yellow)
b	440215	4 LPM Eductor assembly (grey)
		Assemblies include 18c hose barb.
c	3401-R	Eductor hose barb
19 a	10077436	Discharge tube assembly, 4 LPM (not shown — no anti-siphon tee)
b	10074831	Discharge tube assembly, 16 LPM
20*	10080730	Hose hook, dark grey (standard)
	10080731	Hose hook, sky blue
	10080732	Hose hook, red
	10080733	Hose hook, green
	10080734	Hose hook, light grey
	10080735	Hose hook, yellow
		* Hose hooks are for 16 LPM discharge tubes
21	690014	Metering tip (kit)
22	10062550	Tubing, 6mm x 600mm
23	509900	Weight
24	10076301	Foot valve -- Viton (EPDM also available, order 10076302)
NOT SHOWN:		
	10075150	Lock
	10029509	Nut for lock
	10068885	Hole plug (for side cabinet opening)

TROUBLESHOOTING CHART:

Problem	Cause	Solution
1. No discharge	<ul style="list-style-type: none"> a. No water b. Magnetic valve not functioning c. Excessive water pressure d. Eductor clogged 	<ul style="list-style-type: none"> a. Open water supply b. Install valve parts kit c. Install regulator if water pressure exceeds 6 Bar d. Clean* or replace
2. No concentrate draw	<ul style="list-style-type: none"> a. Clogged foot valve b. Metering tip or eductor has scale build-up c. Low water pressure d. Discharge tube and/or flooding ring not in place e. Concentrate container empty f. Inlet hose barb not screwed into eductor tightly g. Clogged water inlet strainer 	<ul style="list-style-type: none"> a. Clean or replace b. Clean (descale)* or replace c. Minimum 1.76 Bar (with water running) required to operate unit correctly d. Push tube firmly onto eductor discharge hose barb, or replace tube if it does not have a flooding ring e. Replace with full container f. Tighten, but do not overtighten g. Disconnect inlet water line and clean strainer
3. Excess concentrate draw	<ul style="list-style-type: none"> a. Metering tip not in place 	<ul style="list-style-type: none"> a. Press correct tip firmly into barb on eductor
4. Failure of unit to turn off	<ul style="list-style-type: none"> a. Water valve parts dirty or defective b. Magnet doesn't fully return c. Push button stuck d. Excessive water pressure 	<ul style="list-style-type: none"> a. Clean* or replace with valve parts kit b. Make sure magnet moves freely. Replace spring if short or weak c. Realign cabinet or clean grommet which button passes through d. Install regulator if pressure exceeds 6 Bar

* In hard water areas, scale may form inside the discharge end of the eductor, as well as in other areas of the unit that are exposed to water. This scale may be removed by soaking the eductor in a descaling solution (deliming solution). To remove an eductor located in the cabinet, firmly grasp vacuum breaker and unthread eductor. Replace in same manner. This will avoid loosening the vacuum breaker. Alternatively, a scaled eductor can be cleaned (or kept from scaling) by drawing the descaling solution through the unit. Operate the unit with the suction tube in the descaling solution. Operate the unit until solution is drawn consistently, then flush the unit by drawing clear water through it for a minute. Replace concentrate container and put suction tube into concentrate.

